

LOC	DIST	REVISIONS			
F	CHR	DESCRIPTION	DATE	OWN	APVD
CM	00	H	REV & REDWN PER EC 0638-0222-99	07-JAN-00	LM KC

- PARTS COMPLY TO AMP SOLDERABILITY SPECIFICATION 109-11-3.
- CIRCUIT IDENTIFICATION CHARACTERS ARE ADJACENT TO THE INDICATED CAVITIES, BUT LOCATION AND ORIENTATION MAY DIFFER FROM PRINT.
- DIMENSIONS IN BRACKETS ARE IN INCHES.

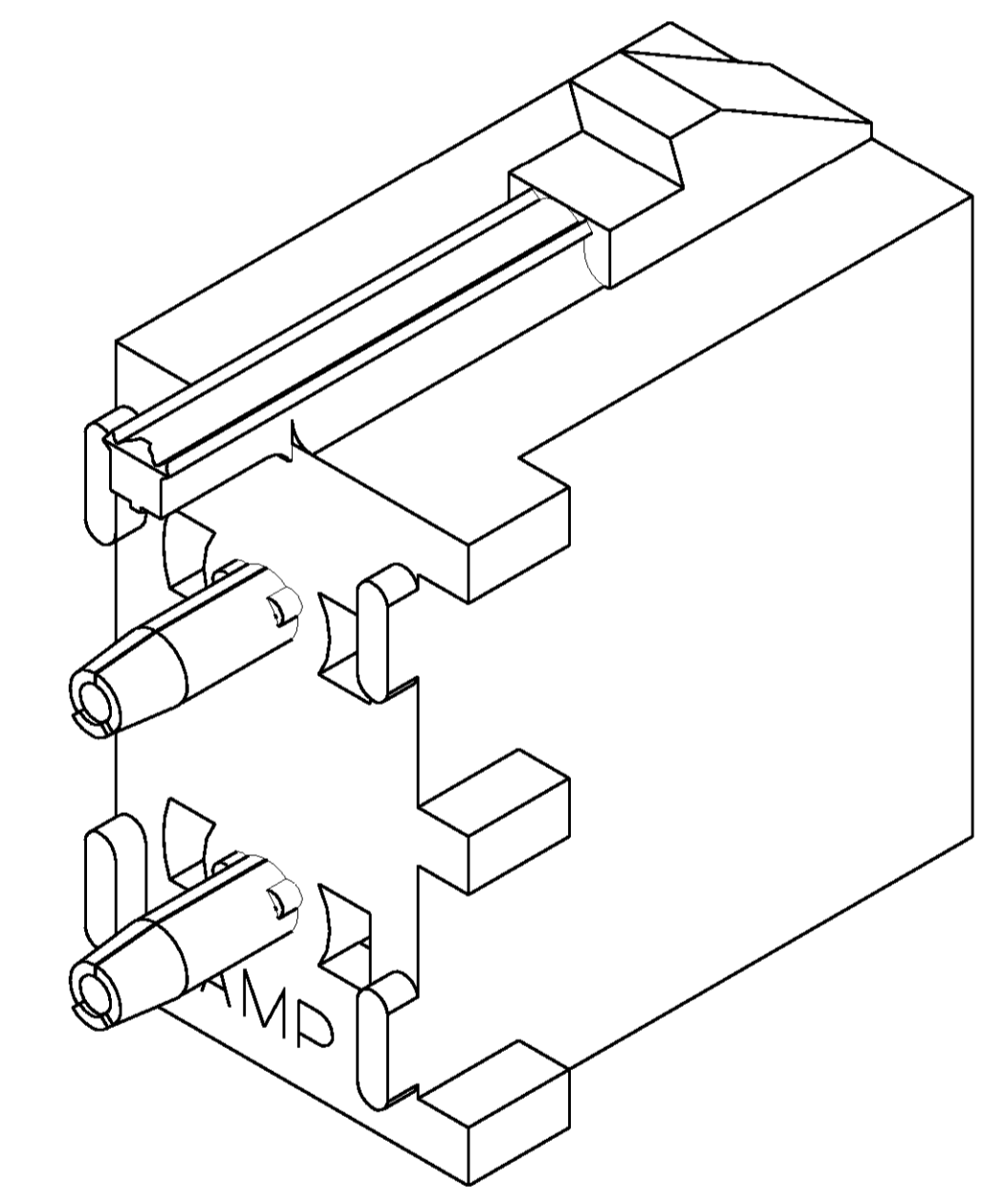

3-DIMENSIONAL MODEL  
NTS

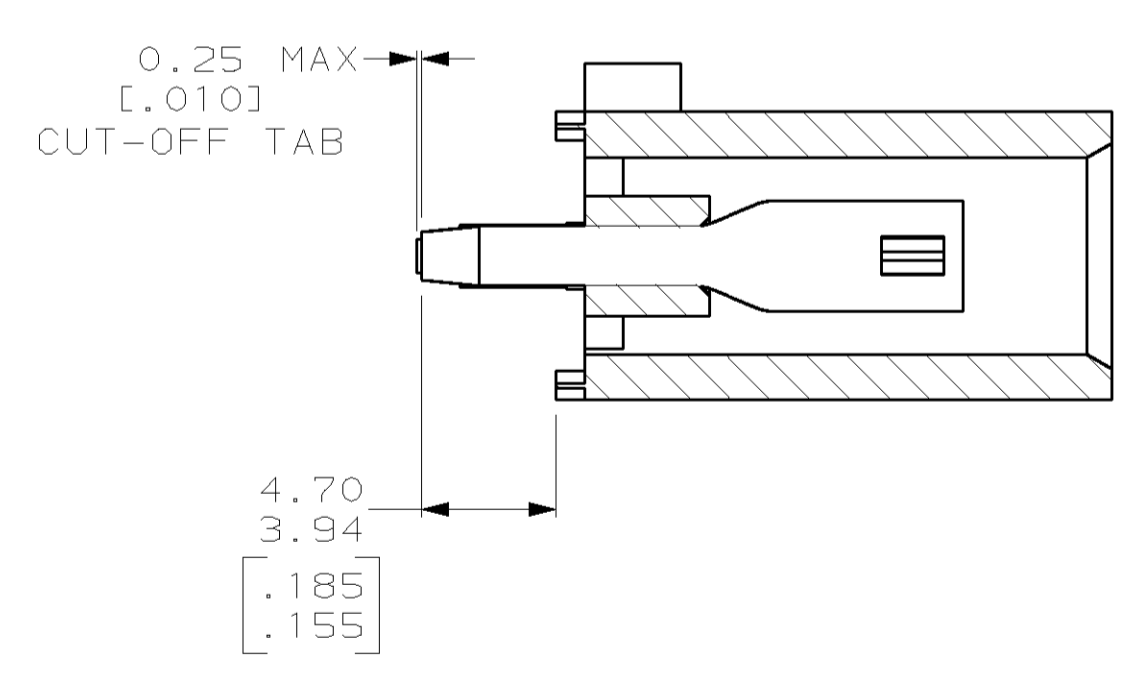
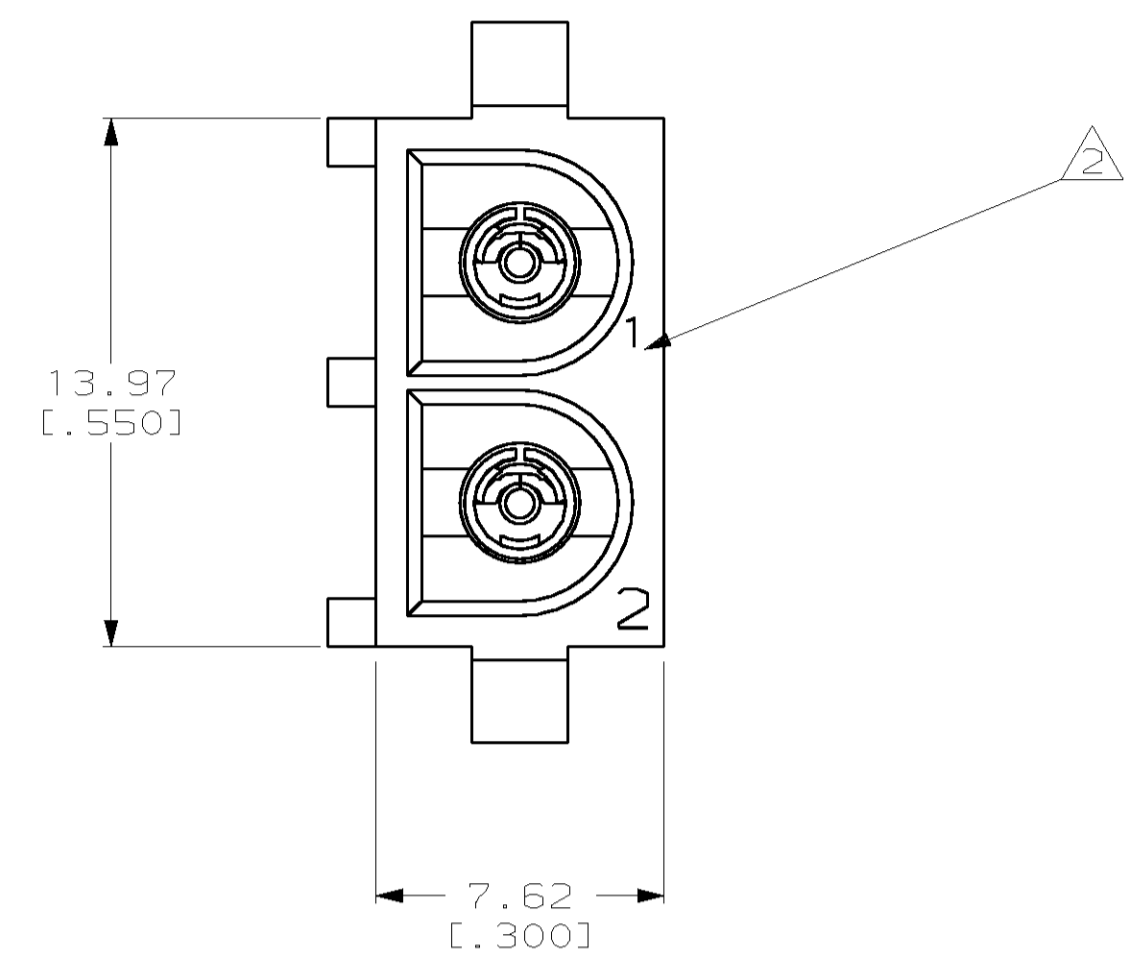
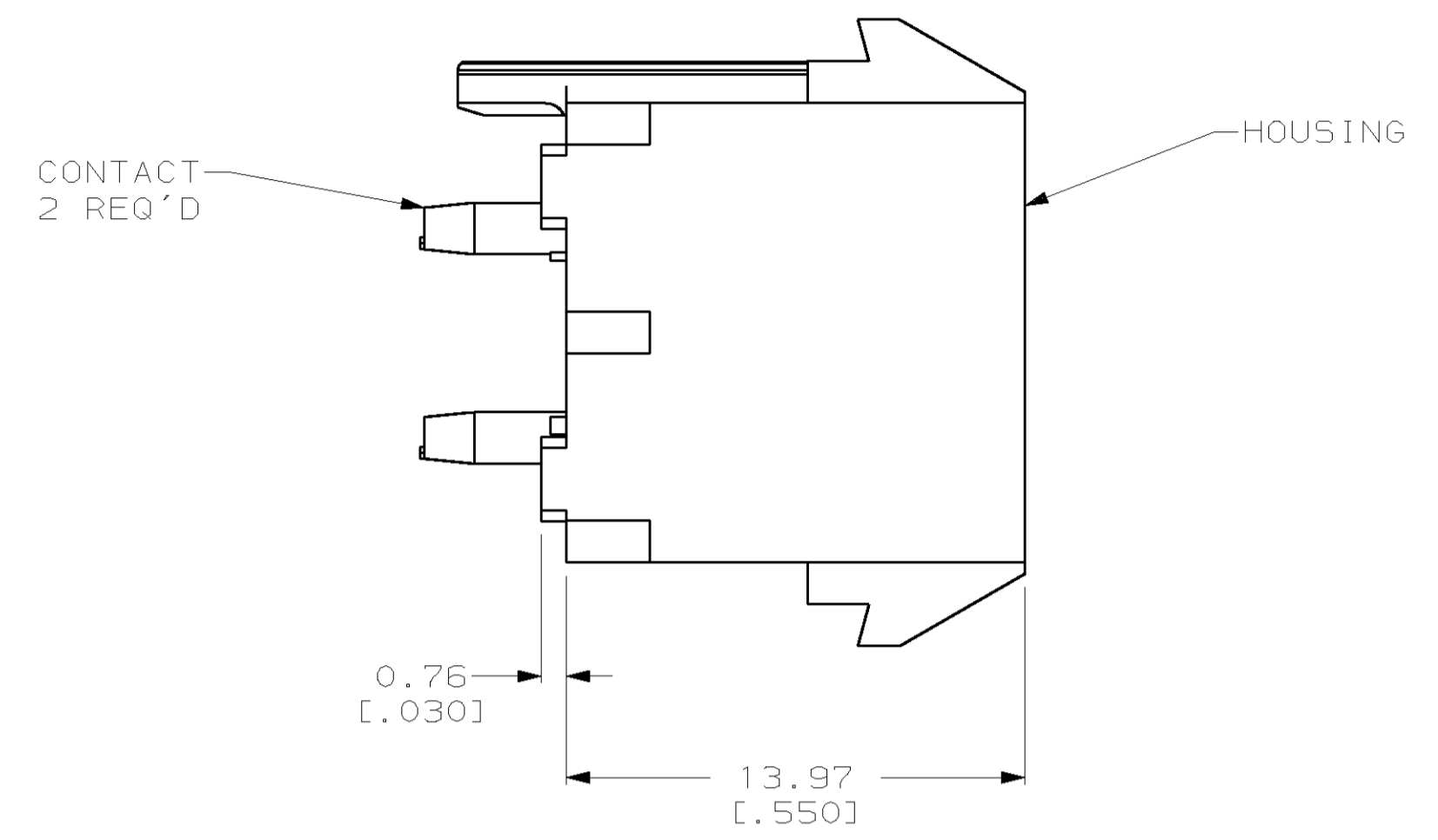
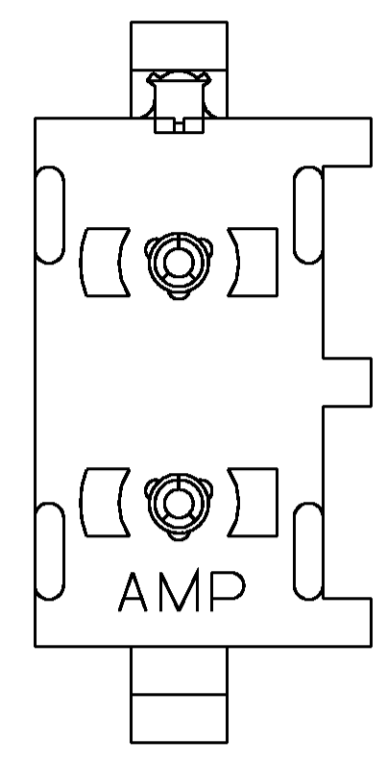
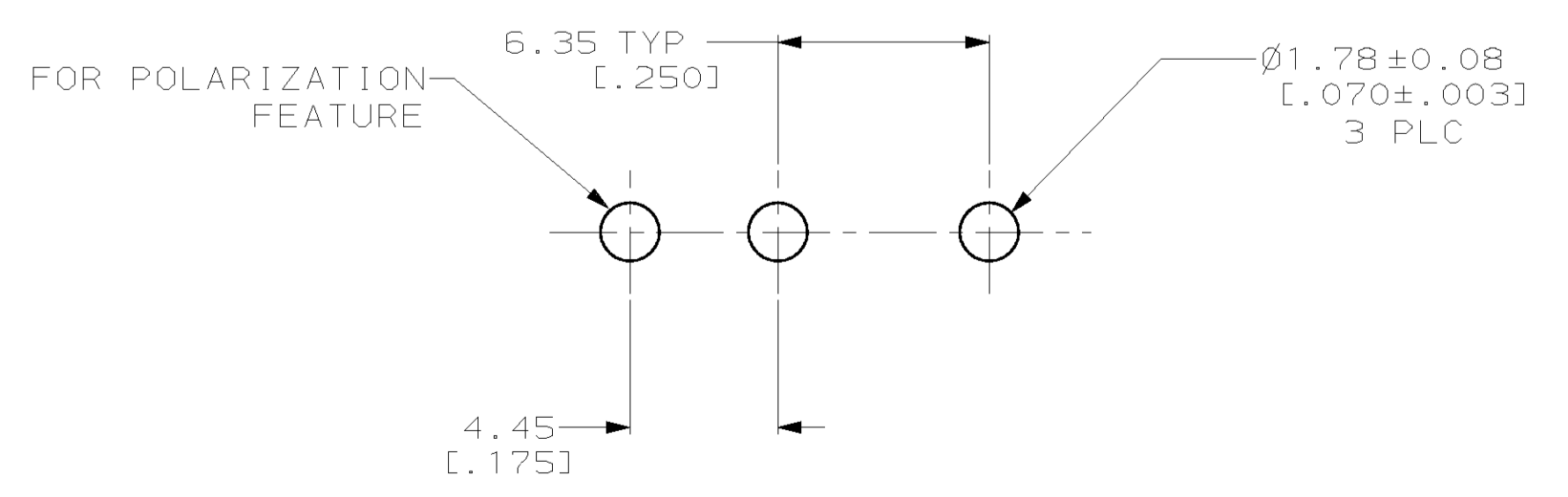

RECOMMENDED MOUNTING HOLE PATTERN  
FOR 1.57 [.062] THICK P.C. BOARD

PHOSPHOR BRONZE, PRE-TIN PIN CONTACT MATERIAL AND FINISH	NYLON, UL94V-2, NATURAL HOUSING MATERIAL	643411-1 PART NO
THIS DRAWING IS A CONTROLLED DOCUMENT.		DWN L. McEACHIN 07-JAN-2000 CHK K. COBLE 07-JUN-2000 NAME AMP Incorporated Harrisburg, PA 17105-3608
DIMENSIONS: mm (INCHES)	TOLERANCES UNLESS OTHERWISE SPECIFIED:	PRODUCT SPEC APPLICATION SPEC SIZE CAGE CODE DRAWING NO A1 00779 C-643411
0 PLC ± 1 PLC ± 2 PLC ±0.13 (.005) 3 PLC ± 4 PLC ± ANGLES 40°-30°	FINISH SEE TABLE	WEIGHT - CUSTOMER DRAWING SCALE 5:1 SHEET 1 OF 1 REV H

